

**ZA13** **0%**  
MERCURY

PR48  
Hearing Aid Battery

Art.No. 100791

# Technical Data Sheet

## Specifications

Chemical system	Zinc / Air
Nominal Voltage	1,45 V
Nominal Capacity	<b>305 mAh</b>
Self Discharge	Less than 5% per year at 20°C with label applied
Weight	~0,9g
Storage / Operating condition	10-30°C / 20-80% r.h. / 0-45°C / 25-70% r.h.

**These batteries need air when they are used Battery compartment must allow free access of air**  
Allow reasonable time between activation (after removable of tab) and commencement of electrical measurement

## Dimensions

(according IEC 60086-2) (Ed.12 Feb. 2011)

Diameter	7.9 mm (0,311")
Height	5,4 mm (0,213")

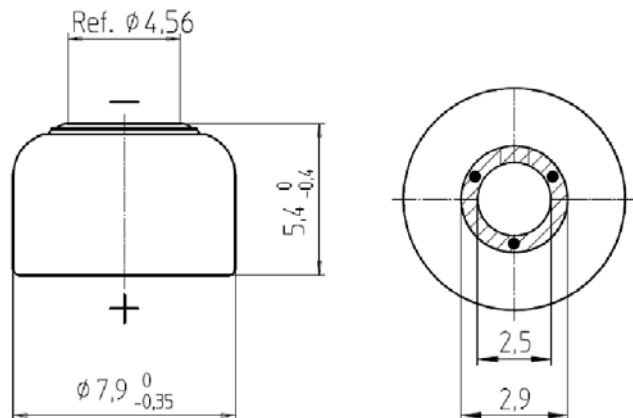

## Discharge Curve

According IEC60086-2 (Ed.12 Feb. 2011)

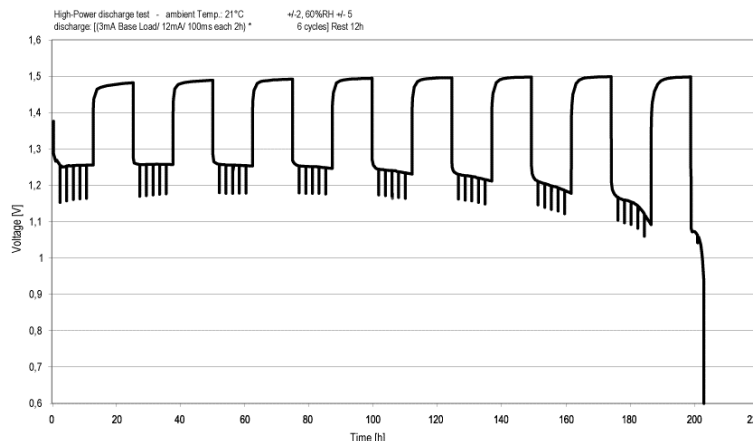

Air-intake holes placement

Information and contents in this data sheet are for reference purpose only. They do not constitute any warranty or representation and are subject to change without notice. For most current information and further details, please contact your Renata representative.